

HEAVY DUTY AIR NEEDLE SCALER

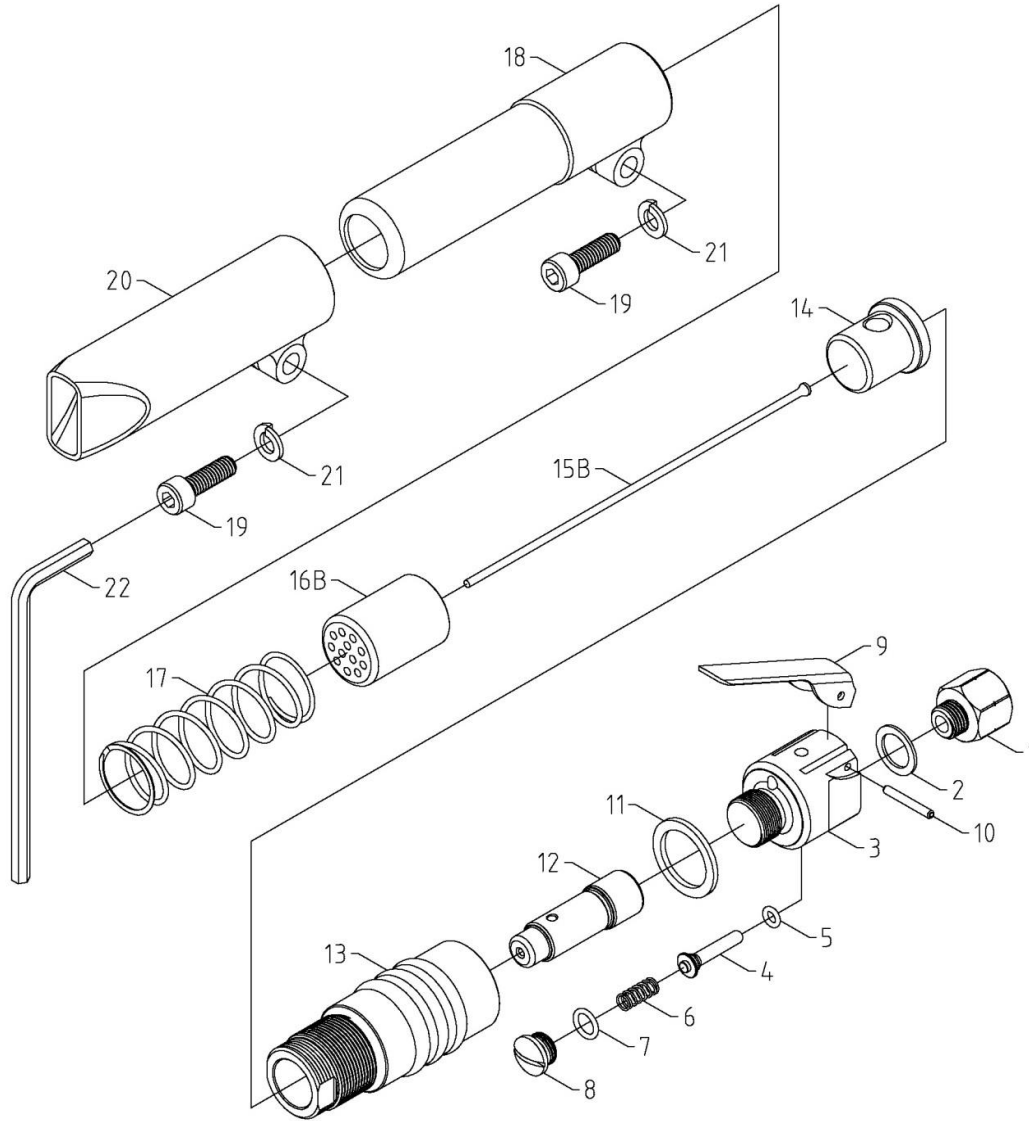

4788-S1 / 4788-S2

INDEX NO.	DESCRIPTION	REQ'D NO.	INDEX NO.	DESCRIPTION	REQ'D NO.
01	Inlet Bushing	1	13	Cylinder	1
02	Washer	1	14	Needle Driver	1
03	Backhead	1	15A	Needle (Ø 2×180L) (For 4788-S1)	27
04	Valve Stem	1	15B	Needle (Ø 3×180L) (For 4788-S2)	12
05	O-Ring	1	16A	Needle Holder (Ø 2×27 Holes) (For 4788-S1)	1
06	Valve Spring	1	16B	Needle Holder (Ø 3×12 Holes) (For 4788-S2)	1
07	O-Ring	1	17	Compression Spring	1
08	Valve Cap	1	18	Intermediate Tube	1
09	Lever	1	19	Cap Head Screw	2
10	Spring Pin	1	20	Front Tube	1
11	Washer	1	21	Spring Washer	2
12	Piston	1	22	Hex. Wrench (6mm)	1

0000.00.00

2019.01.11 2019.07.12